

RD-500VL



Boards Greater Than

680 × 800mm

We Can Provide Customized Solutions
for Your Rework Needs

RD-500VL

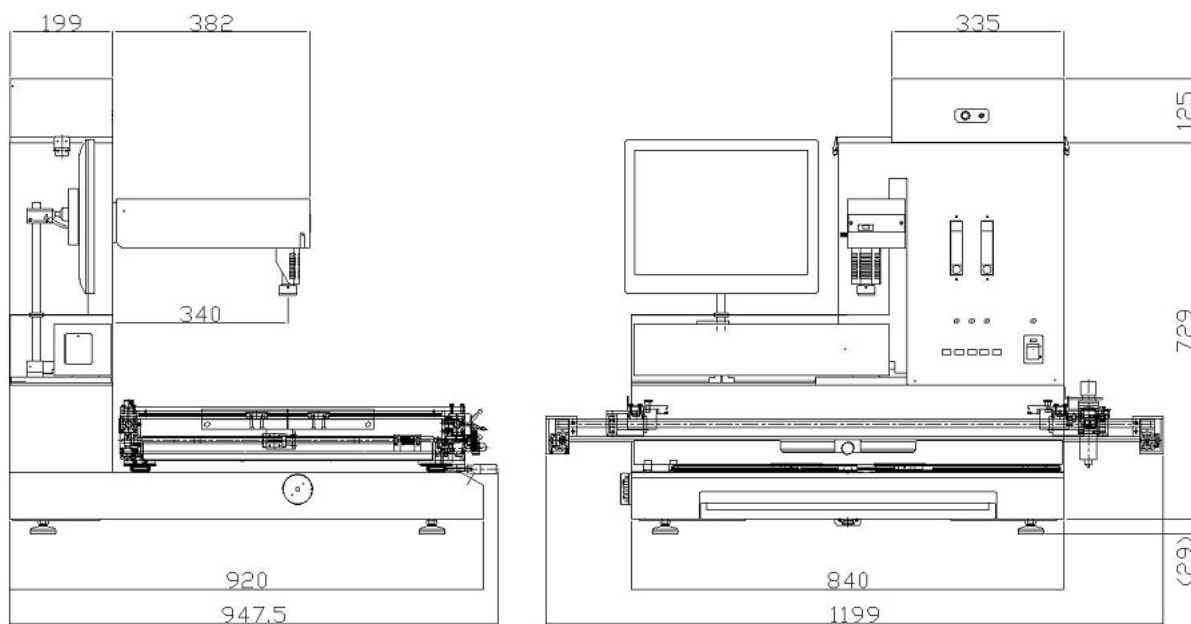

Maximum Board Size	680mm × 800mm(27" x32")
Heating Area	650mm × 750mm(26" x30")
Device Size Range	01005(0402 mm) or more ^{※1}
Placement Accuracy	±0.015mm
Electrical Requirement	AC200-240V 6.8kW / 7.2kW (max)
Top Hot Air Heater	1000W
Bottom Hot Air Heater	1000W
Area Heater	600W × 8 IR 4800W
Temp Setting Range	0 to 650°C
Operating System	Dedicated controller (PC-500Vα)
Monitor	19 inches LCD
External Dimensions	1199W × 947.5D × 883H
Machine Weight	Approx. 109kg (240.30LBs)
Air Requirements	0.6MPa 110L/min (90 PSIG)

※1: Custom nozzles are available

Optional Safety Features

- Safety enclosure with area sensor and door interlock
- Heater temperature over limit visual sensor
- Emergency off switch placed ergonomically in correct location



DEN-ON INSTRUMENTS CO., LTD.

1-26-10, SEKIMACHI HIGASHI, NERIMA-KU, TOKYO 177-0052, JAPAN
 TEL.[81]-3-3929-6000 FAX.[81]- 3-3929-7441
 E-mail: rework@denondic.co.jp

www.denondic.co.jp